

1 x 3 RADIAL FLOW SUPERPHOBIC[®] PRODUCT DATA SHEET

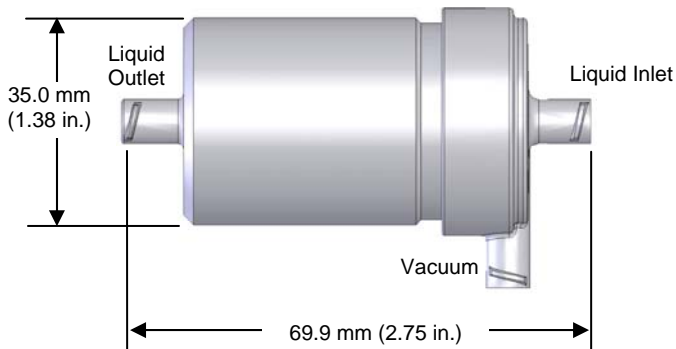
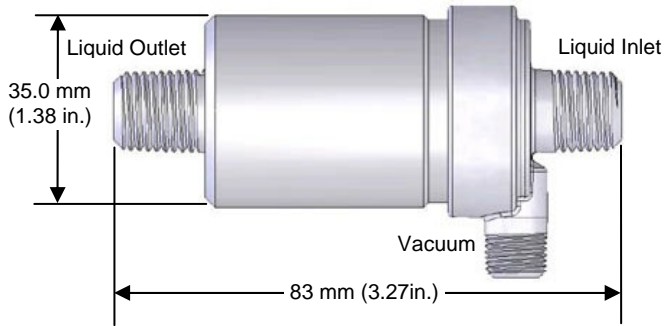

NOTE: All dimensions are nominal values

Cartridge Characteristics	
Cartridge Configuration	No Baffle Radial Flow
Liquid Flow Guidelines <i>(one cartridge)</i>	15 - 60 ml/min (0.004-0.016 gpm) Liquid must flow on the shellside
Membrane/Potting Material	Polyolefin / Polyethylene
Typical Membrane Surface Area	370 cm ² (0.40 ft ²)
Maximum Working Temperature/Pressure	25°C, 3.1 kg/cm ² (3.1 bar) (77°F, 45 psig) 40°C, 15 psig <i>(Using 50 mm vacuum on lumenside)</i>
Priming Volume (approximate)	
Shellside	13 ml
Housing Characteristics	
Material	Black Polyethylene
Connections	
Shellside (Liquid Inlet/Outlet)	<ul style="list-style-type: none"> • 1/4 inch NPT Male • Standard Female Luer Lock
Lumenside (vacuum)	<ul style="list-style-type: none"> • 1/8 inch NPT Male • Standard Female Luer Lock
Weight	
Dry	25 grams (0.06 lbs)

1 x 3 SuperPhobic[®] PRODUCT DATA SHEET

Typical Performance

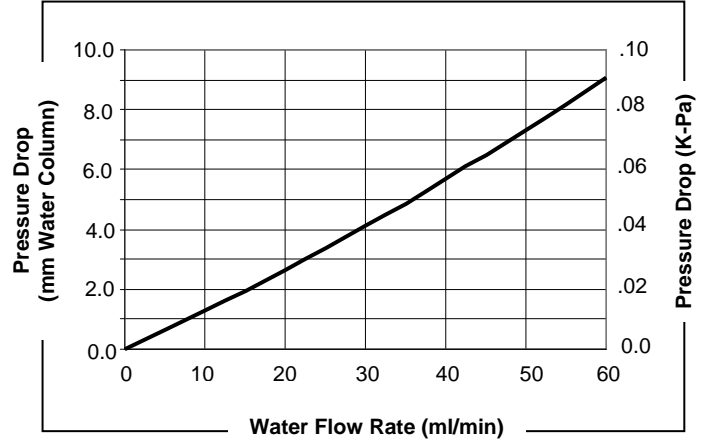
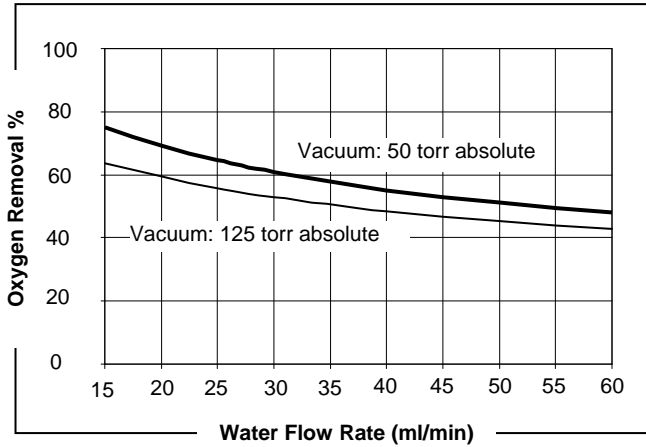

Test Conditions: Deionized water at 20°C.

Pressure drop data for 1 x 3 product with Luer Lock connections.

This product is to be used only by persons familiar with its use. It must be maintained within the stated limitations. All sales are subject to Seller's terms and conditions. Purchaser assumes all responsibility for the suitability and fitness for use as well as for the protection of the environment and for health and safety involving this product. Seller reserves the right to modify this document without prior notice. Check with your representative to verify the latest update. To the best of our knowledge, the information contained herein is accurate. However, neither Seller nor any of its affiliates assumes any liability whatsoever for the accuracy or completeness of the information contained herein. Determination of the suitability of any material and infringement of any third party rights, including patent, trademark, or copyright rights, are the sole responsibility of the user. Users of any substance should satisfy themselves by independent investigation that the material can be used safely. We may have described certain hazards, but we cannot guarantee that these are the only hazards that exist. Nothing herein shall be construed as a recommendation or license to use any information that conflicts with any patent, trademark or copyright of Seller or others. Please read our Operating Manuals carefully before installing and using these modules.

THE INFORMATION CONTAINED HEREIN AND SELLER'S PRODUCTS ARE PROVIDED "AS IS" WITHOUT WARRANTY OF ANY KIND, EITHER EXPRESSED OR IMPLIED, INCLUDING, BUT NOT LIMITED TO, THE IMPLIED WARRANTIES OF MERCHANTABILITY, FITNESS FOR ANY PARTICULAR PURPOSE OR USE, OR NON-INFRINGEMENT OF INTELLECTUAL PROPERTY. IN NO EVENT SHALL SELLER BE LIABLE FOR ANY SPECIAL, INCIDENTAL, INDIRECT, OR CONSEQUENTIAL DAMAGES OF ANY KIND, OR ANY DAMAGES WHATSOEVER RESULTING FROM THE USE OF INFORMATION CONTAINED HEREIN AND SELLER'S PRODUCTS.

Liqui-Cel[®], SuperPhobic[®], MiniModule[®], and MicroModule[®] are registered trademarks of Membrana-Charlotte, A Division of Celgard, LLC.

Copyright © 2011 Membrana – Charlotte

All rights reserved.

(D94_Rev 5)

Membrana - Charlotte
A Division of Celgard, LLC
13800 South Lakes Drive
Charlotte, North Carolina 28273
USA
Phone: (704) 587 8888
Fax: (704) 587 8610

Membrana GmbH
Oehder Strasse 28
42289 Wuppertal
Germany
Phone: +49 202 6099 - 658
Phone: +49 6126 2260 - 41
Fax: +49 202 6099 - 750

Japan Office
Shinjuku Mitsui Building, 27F
1-1, Nishishinjuku 2-chome
Shinjuku-ku, Tokyo 163-0427
Japan
Phone: 81 3 5324 3361
Fax: 81 3 5324 3369

MEMBRANA
A POLYPORE COMPANY

www.liqui-cel.com



ISO 9001
ISO 14001